

| REV | DATE | DESCRIPTION |
|-----|----------|-----------------|
| A | 12/09/19 | INITIAL RELEASE |

THE INFORMATION CONTAINED IN THIS DRAWING IS THE SOLE PROPERTY OF ALTELIX LLC. ANY REPRODUCTION IN PART OR WHOLE WITHOUT THE WRITTEN PERMISSION OF ALTELIX LLC IS PROHIBITED. (C) 2018 ALTELIX LLC.

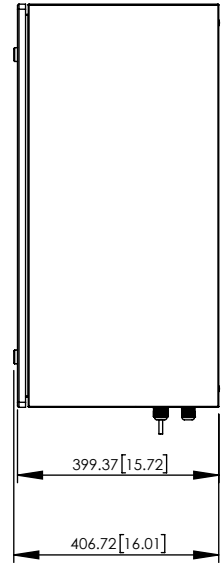

SECTION A-A

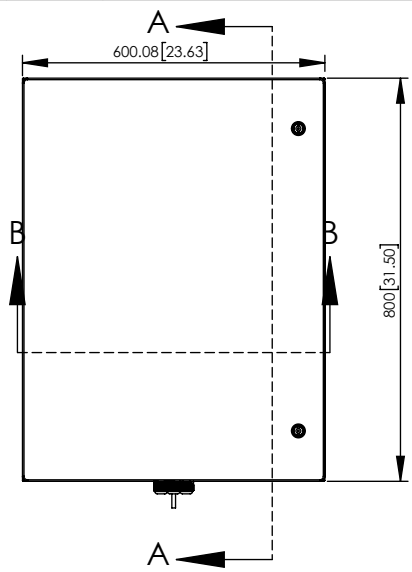
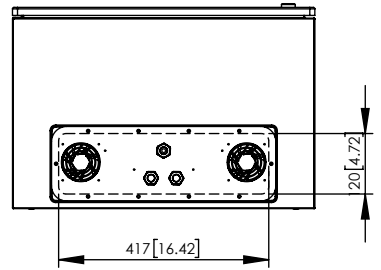
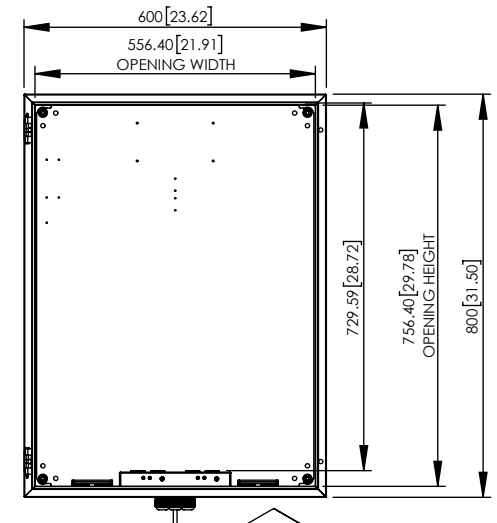
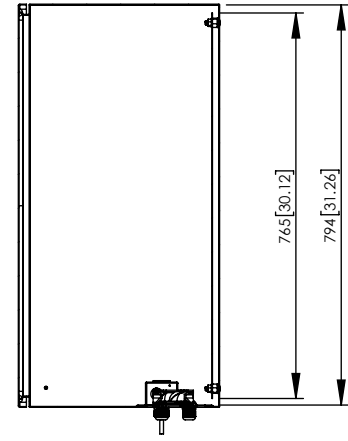

SECTION B-B

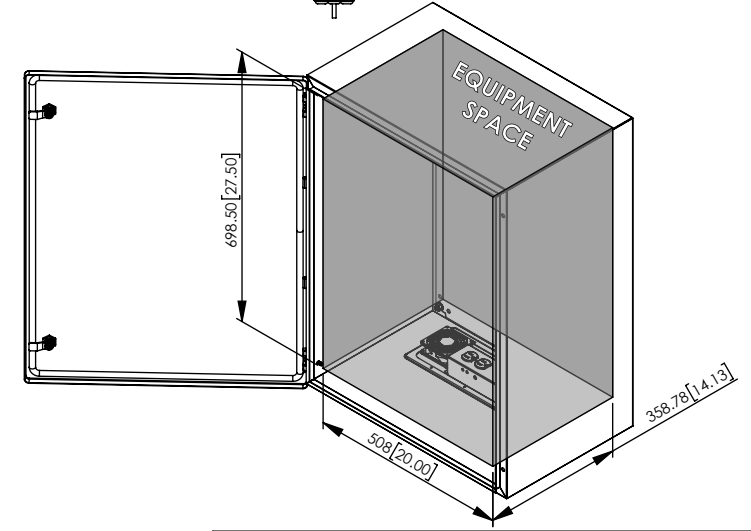
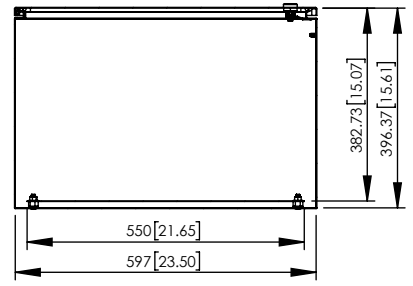

| NO. | DESCRIPTION | MATERIAL | FINISH | QTY. |
|-----|-------------|----------|--------|------|
| 8 | - | - | - | - |
| 7 | - | - | - | - |
| 6 | - | - | - | - |
| 5 | - | - | - | - |
| 4 | - | - | - | - |
| 3 | - | - | - | - |
| 2 | - | - | - | - |
| 1 | - | - | - | - |

UNLESS OTHERWISE SPECIFIED:
 DIMENSIONS ARE IN MILLIMETERS.
 DIMENSIONS IN [] ARE IN INCHES AND
 ARE FOR CUSTOMER REFERENCE ONLY.

TOLERANCES FOR MILLIMETERS:
 0.5-8mm ± 0.20mm
 8-30mm ± 0.40mm
 30-120mm ± 0.50mm

| TASK | NAME | DATE |
|----------|------------|----------|
| DRAWN BY | N. COLUCCI | 12/09/19 |
| CHECKED | - | - |
| APPROVED | - | - |

1201 Clint Moore Road
 Boca Raton, FL 33487
 TEL: 561-660-WIFI
www.altelix.com

| | | | |
|------------------|------|--|---|
| PART DESCRIPTION | | 32 x 24 x 16 PAINTED STEEL ENCLOSURE WITH 120VAC AND FAN | |
| PART NUMBER | | NS322416VFA1C | |
| DRAWING NUMBER | | DRW-NS322416VFA1C | |
| SCALE: | 1:12 | REV: | A |
| | | SHEET 1 OF 1 | |